

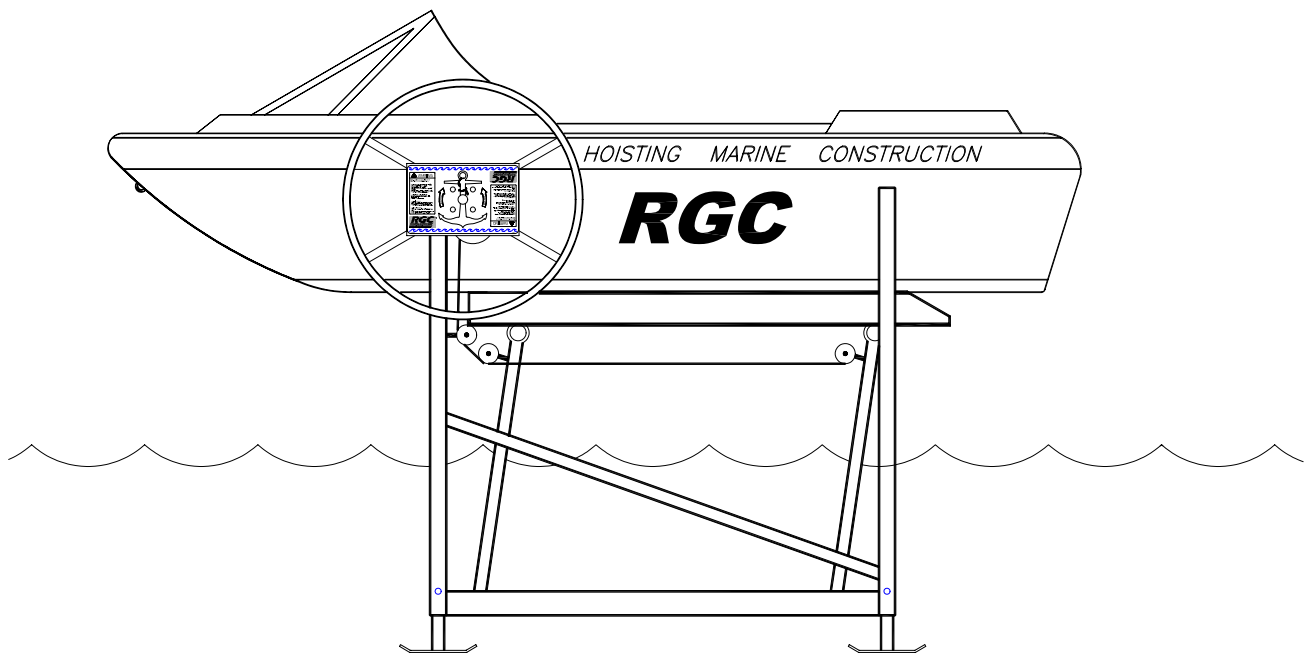

PL2000 BOAT LIFT INSTRUCTIONS



REIMANN & GEORGER CORPORATION
MARINE PRODUCTS
P/N 6112050

BUFFALO, NY
03/09/05

TABLE OF CONTENTS

CHAPTER	TITLE	PAGE
1	SAFETY	1
1.1	Introduction	1
1.2	Safety Definitions	1
1.3	Equipment Safety Labels.....	1
1.4	Equipment and Personnel Safety.....	1
1.5	Installation Safety	1
1.6	Operating Safety	2
1.6.1	General	2
1.6.2	Safety When Raising the Boat Lift.....	2
1.6.3	Safety When Lowering the Boat Lift	3
1.7	Maintenance and Storage Safety	3
2	SPECIFICATIONS.....	4
2.1	Technical Data.....	4
2.2	Nameplate and Serial Number Tag.....	4
2.3	Optional Equipment.....	4
3	INSTALLATION AND SETUP	5
3.1	Pre-Installation Checks.....	5
3.2	Leg Assembly.....	5
3.3	Lifting Platform Assembly	6
3.4	Cross Tie, Diagonal Brace, and Vertical Leg Assembly	7
3.5	Mounting the Winch.....	8
3.5.1	Left Side Winch Mounting.....	8
3.5.2	Right Side Winch Mounting.....	9
3.6	Reeving the Lift.....	10
3.6.1	Left Side Mounted Winch	10
3.6.2	Right Side Mounted Winch	10
3.7	Reeving the Winch	10
3.7.1	Left Side Mounted Winch	10
3.7.2	Right Side Mounted Winch	11
3.8	Wood Bunk Assembly.....	11
3.9	Adjusting the Lift	12
3.10	Final Assembly Checklist.....	13
4	OPERATION.....	14
4.1	Before Operating the Lift	14
4.2	Testing Winch Operation	14
4.3	Raising and Lowering the Platform.....	15
4.4	Securing Lift When Not in Use.....	15
5	INSPECTION AND MAINTENANCE.....	16
5.1	General Maintenance Rules.....	16
5.2	Wire Rope Inspection Procedure.....	16
5.3	Annual Inspection.....	17
5.4	Annual Winch Maintenance	17
5.5	Storage Procedure.....	18
6	TROUBLESHOOTING.....	19
7	PARTS LIST.....	21
7.1	PL2000 BOAT LIFT	21

LIST OF FIGURES

FIGURE	DESCRIPTION	PAGE
2.1	Typical Lift Product Nameplate	4
3.1	Leg and Lifting Platform Assembly	6
3.2	Cross Tie / Diagonal Brace Assembly	7
3.3	Left Side Winch Mounting	8
3.4	Right Side Winch Mounting	9
3.5	Wood Bunk Assembly	12
5.1	Wire Rope Components	17

1 SAFETY

1.1 INTRODUCTION

Your Reimann & Georger Corporation Marine Products Aluminum PL2000 boat lift has been engineered to provide lifting performance, long term economics and safety advantages that no other type can match. However, even a well-designed and well-built lift can malfunction or become hazardous in the hands of an inexperienced and/or untrained user. Therefore, read this manual and related equipment manuals thoroughly before operating your lift to provide maximum safety for all operating personnel, and to get the maximum benefit from your equipment.



WARNING:

DO NOT OPERATE THIS LIFT WITHOUT STUDYING THIS ENTIRE MANUAL. FAILURE TO DO THIS CAN LEAD TO EQUIPMENT MISUSE WITH RESULTING DAMAGE AND/OR SERIOUS PERSONAL INJURY. CONTACT YOUR RGC® MARINE DEALER IF YOU HAVE ANY QUESTIONS.

1.2 SAFETY DEFINITIONS

A safety message alerts you to potential hazards that could hurt you or others or cause property damage. The safety messages or signal words for product safety signs are **DANGER**, **WARNING**, and **CAUTION**. Each safety message is preceded by a safety alert symbol and is defined as follows:

DANGER: Indicates an imminently hazardous situation, which, if not avoided, **will** cause death or serious injury. This safety message is limited to the most extreme situations.

WARNING: Indicates potentially hazardous situation which, if not avoided, **could** result in death or serious injury.

CAUTION: Indicates a potentially hazardous situation which, if not avoided, **may** result in minor or moderate injury. It may also be used to alert against unsafe practices and property-damage-only accidents.

1.3 EQUIPMENT SAFETY LABELS

These labels warn you of potential hazards which could cause injury. Read them carefully. If a label comes off or becomes illegible, contact a Reimann & Georger Corporation dealer for a free replacement.

1.4 EQUIPMENT AND PERSONNEL SAFETY

1. Do not use the lift if it shows any signs of damage.
2. Do not exceed the rated maximum lifting capacity of this equipment.



WARNING:

DO NOT STAND OR WALK ON THE LIFT PLATFORM WHILE IT IS IN ANY RAISED POSITION. THIS CAN CAUSE SERIOUS PERSONAL INJURY.

Do not allow anyone to swim or play under, near or on the lift at any time.

1.5 INSTALLATION SAFETY

1. Insure that all bolts and nuts are fastened securely prior to operation.
2. Ensure the pulleys spin freely. If any pulley binds, replace it immediately.
3. Do not weld or otherwise modify the lift. Such alterations may weaken the structural integrity of the lift and void the warranty.
4. Ensure that the frame is square and that the lift sits level.



WARNING:

IF THE FRAME IS NOT SQUARE OR THE LIFT IS NOT LEVEL, BINDING MAY RESULT. THIS CAN CAUSE EQUIPMENT DAMAGE AND/OR PERSONAL INJURY.

1.6 OPERATING SAFETY

1.6.1 General



WARNING:

NEVER USE THIS EQUIPMENT BEYOND ITS RATED CAPACITY OF 2000 LBS. THIS CAN DAMAGE THE LIFT AND/OR BOAT WITH RESULTING SERIOUS PERSONAL INJURY.

1. Before allowing anyone to operate the lift, be certain they fully understand the proper operating procedure.
2. Completely remove any user or dealer installed locking devices before operating the lift.



CAUTION:

DO NOT TRY LIFTING OR LAUNCHING YOUR BOAT IN ROUGH WATER CONDITIONS. THIS CAN DAMAGE YOUR BOAT AND/OR THE LIFT.



WARNING:

THE BOAT MUST BE SECURED ON THE LIFT BEFORE RAISING OR LOWERING. FAILURE TO DO THIS CAN CAUSE EQUIPMENT DAMAGE AND/OR SERIOUS PERSONAL INJURY.

3. Keep people and pets clear during operation of the lift.
4. Keep fingers and clothing clear of all moving parts.
5. Check the lift periodically for frayed cables and/or binding pulleys.



WARNING:

WEAR HEAVY LEATHER GLOVES WHEN HANDLING WIRE ROPE. INSUFFICIENT HAND PROTECTION WHEN HANDLING WIRE ROPE CAN CAUSE SERIOUS PERSONAL INJURY.

6. Do not attempt to make any adjustments on the lift while it is being operated.
7. Contact your dealer if the winch mechanism fails to perform as described in the Operation chapter of this manual.



CAUTION:

NEVER TAMPER WITH THE WINCH MECHANISM. THIS CAN CAUSE EQUIPMENT DAMAGE THAT WILL INVALIDATE YOUR WARRANTY.

8. Do not operate the lift under the influence of drugs, alcohol, or medication.
9. Never use the lift to hang or store any auxiliary equipment such as boating hardware.

1.6.2 Safety When Raising the Boat

The handwheel must turn clockwise when raising the platform. The brake pawl must click, indicating that the brake is operative.



CAUTION:

IF YOU HAVE TO TURN THE HANDWHEEL COUNTERCLOCKWISE TO RAISE THE PLATFORM, YOU HAVE REEVED THE WINCH INCORRECTLY. YOU WILL IMMEDIATELY ENCOUNTER STRONG RESISTANCE WHICH CAN LEAD TO WINCH DAMAGE AND/OR CABLE BREAKAGE.



WARNING:

DO NOT TRY TO INCREASE THE MAXIMUM LIFTING HEIGHT OF THE PLATFORM BEYOND THAT PERMITTED BY THE STOP ANGLE. THIS CAN CAUSE EQUIPMENT DAMAGE AND/OR SERIOUS PERSONAL INJURY.

1.6.3 Safety When Lowering the Boat

1. The handwheel must turn counter-clockwise when lowering the platform.



WARNING:

IF YOU HAVE TO LOWER THE PLATFORM BY TURNING THE HANDWHEEL CLOCKWISE, YOU HAVE REEVED THE WINCH INCORRECTLY. THE BRAKE PAWL WILL NOT BE EFFECTIVE WHICH CAN CAUSE AN UNCONTROLLED SPIN-DOWN OR “FREEWHEEL” OF THE HANDWHEEL. IF FREEWHEELING OCCURS, NEVER TRY TO STOP IT.

2. Counter-clockwise rotation of the handwheel allows the self-activating brake mechanism to provide a controlled lowering of the platform. The winch is designed so that you never have to flip any ratchets before lowering the platform. Before attempting to lower the boat, make sure the brake mechanism is operative using the test discussed in detail in Chapter 4.



WARNING:

NEVER RELEASE THE BRAKE PAWL OF THE WINCH. THIS CAN TRIGGER AN UNCONTROLLED SPIN-DOWN OR “FREEWHEEL” OF THE HANDWHEEL.



CAUTION:

DO NOT CONTINUE LOWERING THE PLATFORM AFTER THE BOAT FLOATS FREELY FROM IT OR IF THE WINCH CABLE GOES SLACK. THIS MAY CAUSE LIFT AND WINCH DAMAGE.

1.7 MAINTENANCE AND STORAGE SAFETY

1. At least once a year, the lift must be thoroughly inspected as described in the Maintenance chapter of this manual.



WARNING:

THE WINCH MAINTENANCE SCHEDULE MUST BE FOLLOWED TO AVOID POSSIBLE EQUIPMENT FAILURE OR PERSONAL INJURY. SEE CHAPTER 5 FOR MAINTENANCE INFORMATION.

2. Completely lower the platform before performing any type of maintenance or repair.



WARNING:

NEVER ALLOW ANYBODY TO WORK IN OR ON THE BOAT WHEN IT IS SUSPENDED ABOVE THE WATER ON THE LIFT.

3. Immediately replace any components found to be defective as described in Chapter 5—Inspection and Maintenance.

2 SPECIFICATIONS

2.1 TECHNICAL DATA

Capacity	2000 lbs.
Max. Beam	105"
Lifting Height	46"
Bed Length	120"
Overall Width	112"
Adjustable Legs	4 @ 18"
Shipping Weight	426 lbs.

2.2 NAMEPLATE AND SERIAL NUMBER TAG

It is important to identify your lift completely and accurately whenever ordering spare parts or requesting assistance in service. The lift has a product nameplate located on the vertical leg. The label shows the model and serial numbers and capacity rating. The lift label should appear as the sample nameplate shown in Figure 2-1. Record the model and serial numbers, and capacity rating for future reference.

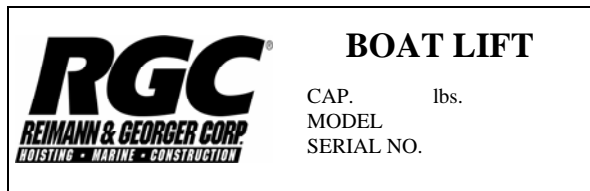

Figure 2-1.
Typical Lift Product Nameplate

MODEL PL2000

SERIAL NUMBER _____

CAPACITY RATING 2000 LBS.

2.3 OPTIONAL EQUIPMENT

The following options are available which enable you to customize your lift for your particular operation. Installation instructions are provided as part of each option kit.

1. **Deep Water Extension Legs**—Adjustable legs available in pairs. Standard lengths are 3', 4', and 5' —no feet.
2. **Roller Guide-Ons**—Cushioned guide-ons make entering the lift easy in various water conditions.
3. **Pontoon Brackets**—Pontoon brackets designed for lifting pontoon boats from under the pontoons. Wood for bunks is not supplied.
4. **Acrylic Canopy**— Boats tucked neatly under the heavy duty canopy are protected from the elements, reducing the need for boat coverings. Various canopy colors are available.

3 INSTALLATION AND SETUP

The reference numbers and letters used in the subassembly drawings of Chapter 3 are the same as those listed in the parts lists of Chapter 7.

3.1 PRE-INSTALLATION CHECKS

1. Do not assemble the lift if any part shows any sign of damage.
2. Do not weld or otherwise modify the lift. Such alterations may weaken the structural integrity of the lift and void the warranty.
3. Where it is specified to use a flat washer, split-lock washer and hex nut on bolted connections, make sure that they are assembled onto the bolt in the stated order to insure proper clamping forces between assembled components.



CAUTION:

DO NOT EXCEED THE MAXIMUM TORQUE RATING ON ALL BOLTS OF 20 FT-LBS.

3.2 LEG ASSEMBLY

1. Refer to **Figure 3-1**. Attach foot plate to extension leg as shown in **Detail A**. Repeat procedure for all four foot plates.
2. Insert extension legs in the stern end and bow end of the side assemblies keeping the nut-end of the bolts facing inward for safety.
3. Insert square nuts into the captured nut housings of both side assemblies as shown in **Detail B** and secure using specified hex head cap screw. Repeat procedure at all four corners of the lift. This screw/nut assembly is a locking device for the adjustable extension legs.

3.3 LIFTING PLATFORM ASSEMBLY

1. Refer to **Figure 3-1**. Insert plastic caps onto the tube ends containing the pivot bunk mounting brackets of the lifting arms.
2. Insert lifting arms into the bearings of each side assembly. Orient the bow and stern lifting arms such that, when they are in the upright position, the mounting holes for the polymer blocks are angled downward as shown in **Detail C**.

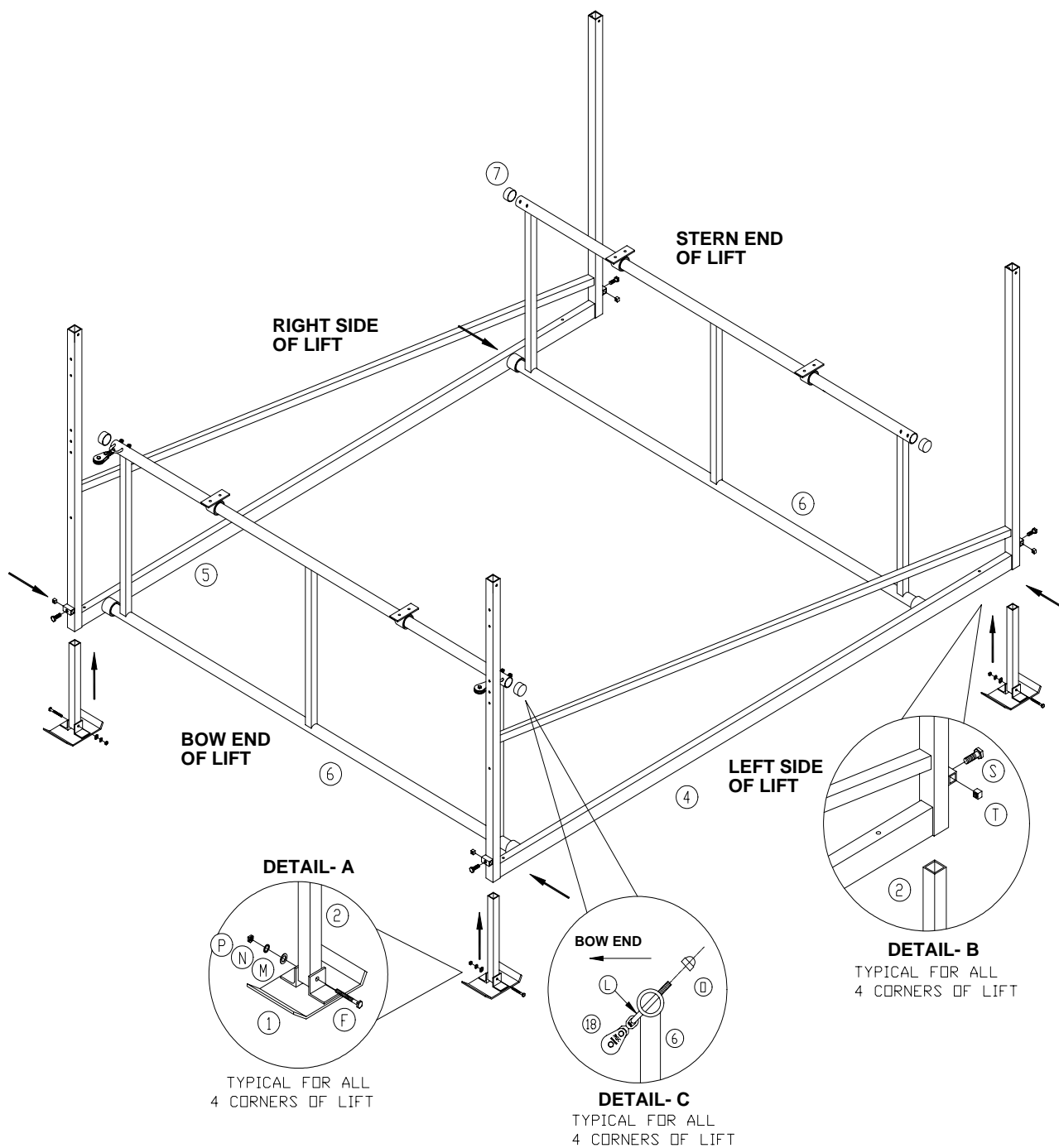

Figure 3-1.
Leg / Lift Platform Assembly

3.4 CROSS TIES, DIAGONAL BRACES, AND VERTICAL LEG ASSEMBLY

1. Refer to **Figure 3-2**. Attach stern end cross tie and two cross diagonals to **underside** of side assemblies as shown in **Detail D**.



CAUTION:

IF THE STERN CROSS TIE IS INCORRECTLY MOUNTED TO THE TOPSIDE OF SIDE ASSEMBLIES, THE CROSS TIE WILL INTERFERE WITH TRAILING ARM & REDUCE PLATFORM TRAVEL.

2. Attach two cross diagonals between **underside** of side assembly and bow end lower cross tie. Attach bow end cross ties to both **topside and underside** of side assemblies as shown in **Detail E**.
3. Fasten all four cross diagonals together at center of lift as shown in **Detail L**.
4. Attach lower diagonal braces between upper bow end cross tie and vertical side frame post as shown in **Detail F**.
5. Attach stop angle brackets to bow end of both side frame assemblies as shown in **Detail G**.

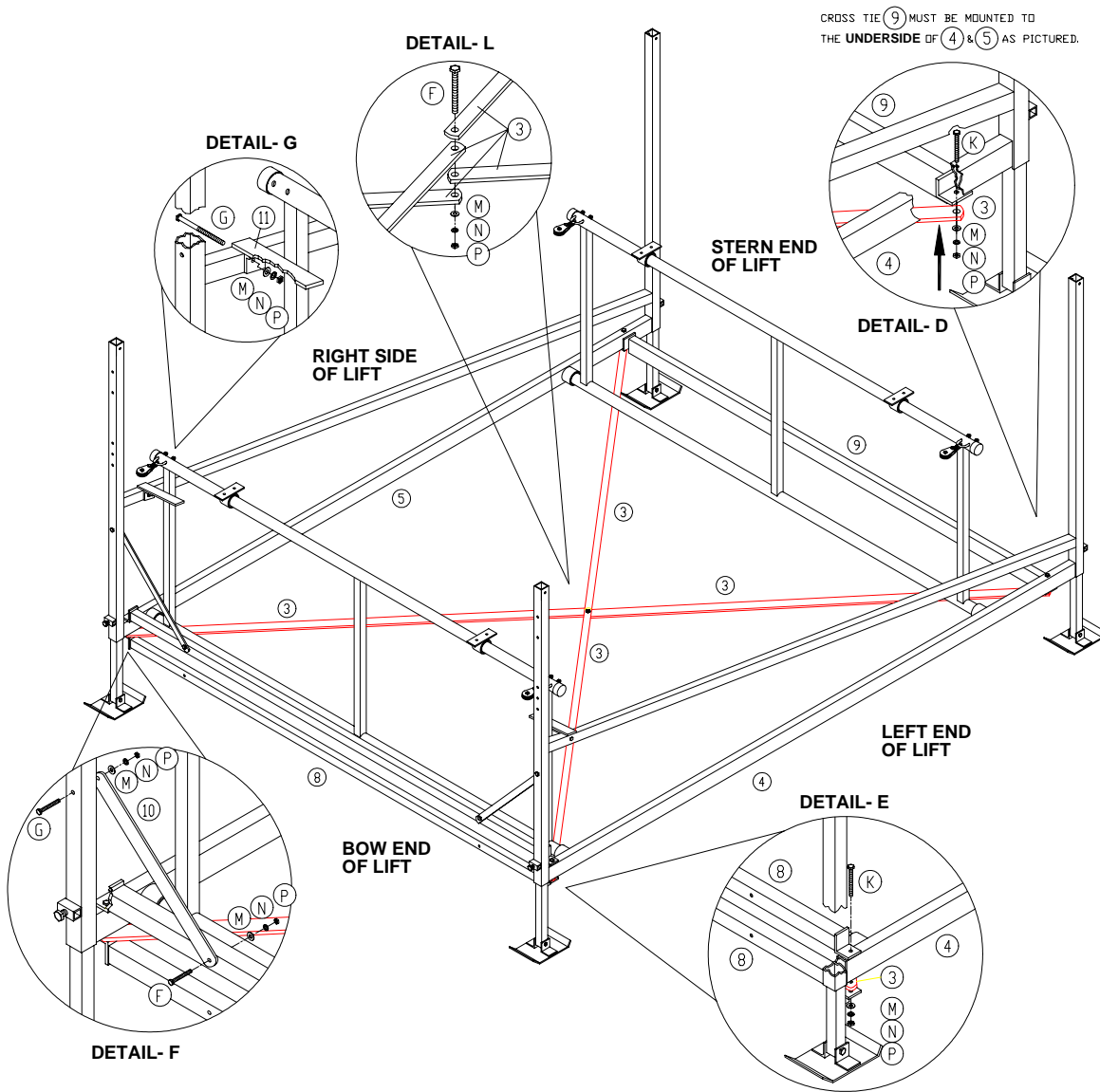

Figure 3-2.
Cross Tie / Diagonal Brace Assembly

3.5 MOUNTING THE WINCH



CAUTION:

FOR RIGHT AND LEFT SIDE WINCH INSTALLATIONS, THE WINCH MUST BE MOUNTED LEVEL AND PLUMB TO SIDE ASSEMBLIES WITH INPUT SHAFT FACING OUTSIDE OF LIFT. INSURE THAT CLOCKWISE ROTATION OF HANDWHEEL RAISES LIFTING PLATFORM.

3.5.1 LEFT SIDE WINCH MOUNTING

1. Making sure that input shaft is facing towards outside of lift, attach winch to bow end of left side frame assembly as shown in **Figure 3-3**.
2. Place backer plate between winch and frame post.
3. Place the winch stiffener plate inside the winch.



CAUTION:

DO NOT REMOVE ANY PREASSEMBLED HARDWARE FOR THE WINCH ADAPTER PLATE. IT HAS BEEN PRESET BY THE MANUFACTURER FOR PROPER WINCH OPERATION.

4. Attach handwheel to winch adapter plate (pre-assembled on the winch input shaft) as shown in **Detail H**.
5. Attach the spinner knob to the handwheel using the pre-assembled hardware as shown in **Detail H**. Select the hole in the handwheel spoke that is most comfortable for lowering the lift.

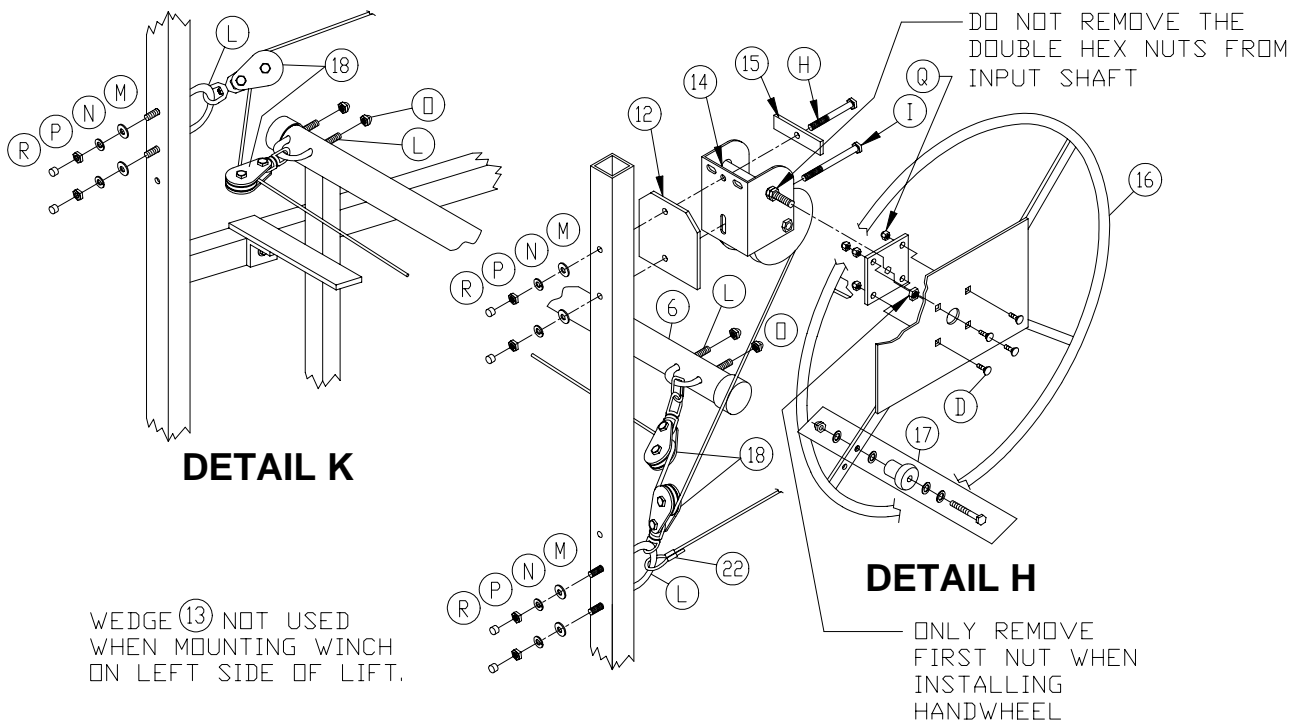

Figure 3-3.
Left Side Winch Mounting

3.5.2 RIGHT SIDE WINCH MOUNTING



CAUTION:

THE WINCH WEDGE MUST BE INSTALLED WHEN MOUNTING THE WINCH ON THE RIGHT SIDE OF THE LIFT TO PROVIDE CABLE CLEARANCE INSIDE THE WINCH AND CLEARANCE FROM THE VERTICAL LEG.

1. Making sure that input shaft is facing towards outside of lift, attach winch to bow end of right side frame assembly as shown in **Figure 3-4**.
2. Place winch wedge between backer plate and frame post.

- Place the winch stiffener plate inside the winch.



CAUTION:

DO NOT REMOVE ANY PREASSEMBLED HARDWARE FOR THE WINCH ADAPTER PLATE. IT HAS BEEN PRESET BY THE MANUFACTURER FOR PROPER WINCH OPERATION.

- Attach handwheel to winch adapter plate (pre-assembled on the winch input shaft) as shown in **Detail I**.
- Attach the spinner knob to the handwheel using the pre-assembled hardware as shown in **Detail I**. Select the hole in the handwheel spoke that is most comfortable for raising and lowering the lift.

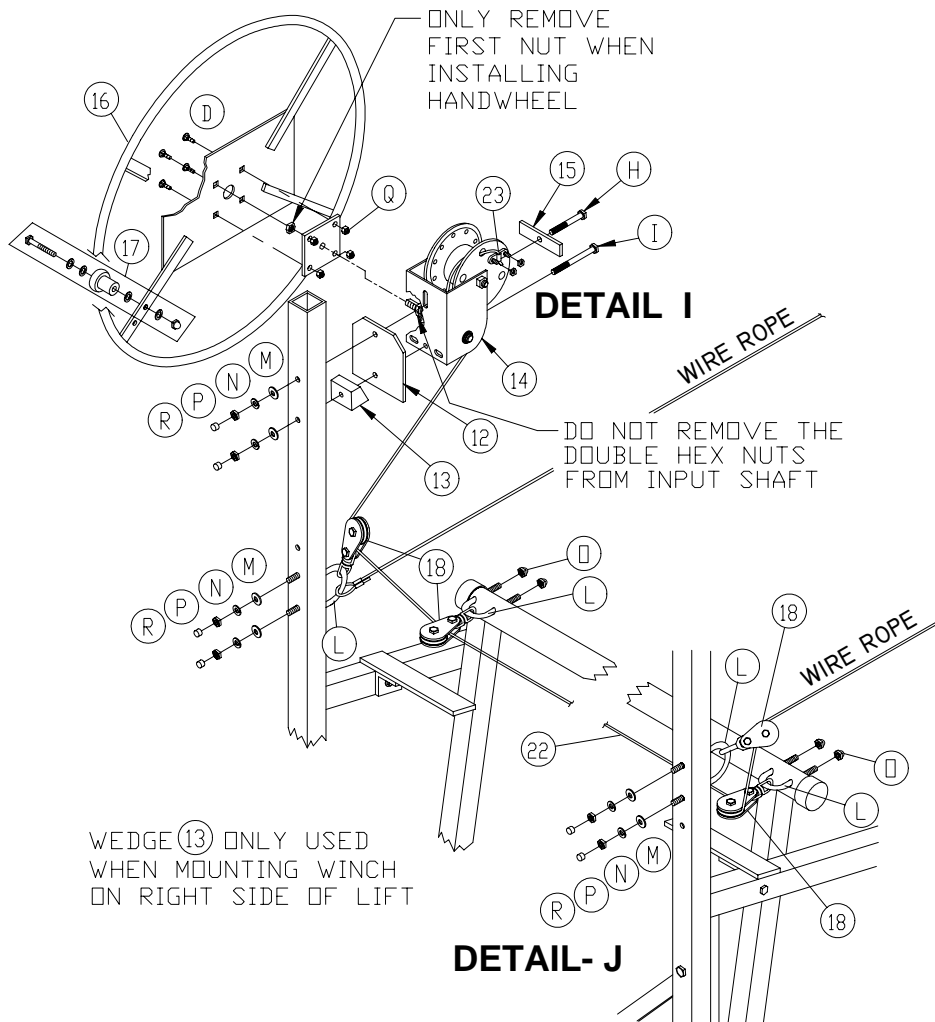

Figure 3-4.
Right Side Winch Mounting

3.6 REEVING THE LIFT



WARNING:

WEAR HEAVY LEATHER GLOVES WHEN HANDLING WIRE ROPE. INSUFFICIENT HAND PROTECTION WHEN HANDLING WIRE ROPE CAN CAUSE SERIOUS PERSONAL INJURY.

3.6.1 Left Side Mounted Winch

1. Refer to **Figure 3-1. Detail C**. Insert a U-bolt through the swivel of a polymer block. Install a U-bolt and polymer block on each end of both lifting arm assemblies. Insure U-bolts are angled downward facing the bow end when the lifting arms are in the upright position.
2. Refer to **Figure 3-3 Detail H and Figure 3-5**. Install polymer block on left-hand side assembly by inserting U-bolt through the swivel of the polymer block and loop end of wire rope attaching it to bow end corner **D** of the side assembly using the lower set of mounting holes.
3. Refer to **Figure 3-3 Detail K**. Install polymer block on right-hand side assembly by inserting U-bolt through the swivel of the polymer block attaching it to bow end corner **A** of the side assembly using the upper set of mounting holes.
4. Refer to **Figure 3-5**. Reeve wire rope through polymer blocks in the following order. Starting from bow corner **D**, proceed to stern corner **C**, then across to stern corner **B**, and ahead to bow corner **A**. At corner **A** reeve side assembly block first, then reeve lift arm block. Next return to bow corner **D**, reeving lift arm block then side frame block finishing at winch as shown in **Detail H of Figure 3-3**.

3.6.2 Right Side Mounted Winch

1. Refer to **Figure 3-1. Detail C**. Insert a U-bolt through the swivel of a polymer block. Install a U-bolt and polymer block on each end of both lifting arm assemblies. Insure U-bolts are angled downward facing the bow end when the lifting arms are in the upright position.
2. Refer to **Figure 3-4 Detail I and Figure 3-5**. Install polymer block on right-hand side assembly by inserting U-bolt through the swivel of the polymer block and loop end of wire rope attaching it to bow end corner **A** of the side assembly using the lower set of mounting holes.
3. Refer to **Figure 3-4 Detail J**. Install polymer block on left-hand side assembly by inserting U-bolt through the swivel of the polymer block attaching it to bow end corner **D** of the side assembly using the upper set of mounting holes.
4. Refer to **Figure 3-5**. Reeve wire rope through polymer blocks in the following order. Starting from bow corner **A**, proceed to stern corner **B**, then across to stern corner **C**, and ahead to bow corner **D**. At corner **D** reeve side assembly block first, then reeve lift arm block. Next return to bow corner **A**, reeving lift arm block then side frame block finishing at winch as shown in **Figure 3-4. Detail I**.

3.7 REEVING THE WINCH

3.7.1 Left Side Mounted Winch

1. Refer to **Figure 3-4**. Install the wire rope clamp, outside the drum flange as shown in **Detail I**. Do not tighten at this time.
2. Refer to **Figure 3-3**. Feed the wire rope over the back side of the drum, through hole in drum flange and under the wire rope clamp with one inch extending past the clamp as shown in **Detail I of Figure 3-4**. Tighten nuts on clamp to hold wire rope in place.
3. When reeving the wire rope onto the drum, keep it flush with drum wall with minimal gaps between wraps. Insure the wire rope does not rub against any part of the winch frame or vertical leg.



CAUTION:

INSURE WINCH BRAKE PAWL AUDIBLY “CLICKS” WHEN RAISING THE PLATFORM TO VERIFY PROPER OPERATION.



WARNING:

WHEN REEVING THE WIRE ROPE ONTO THE DRUM, INSURE CLOCKWISE ROTATION OF THE HANDWHEEL RAISES THE PLATFORM.

3.7.2 Right Side Mounted Winch

1. Refer to **Figure 3-4**. Install the wire rope clamp, outside the drum flange as shown in **Detail I**. Do not tighten at this time.
2. Refer to **Figure 3-4**. Feed the wire rope into the winch between winch frame and front side of drum. Continue reeving wire rope over drum, through hole in drum flange and under the wire rope clamp with one inch extending past the clamp as shown in **Detail I**. Tighten nuts on clamp to hold wire rope in place.
3. When reeving the wire rope onto the drum, keep it flush with drum wall with minimal gaps between wraps. Insure the wire rope does not rub against any part of the winch frame or vertical leg.

3.8 WOOD BUNK ASSEMBLY

1. For ease of assembly, raise the lifting arms to approximately waist level to provide easy access to wood bunk mounting locations.
2. Refer to **Figure 3-5**. Set distance of each pivot bunk mounting bracket a minimum of 10" from center of bow and stern lifting arm. Then mount a pair of half round clamps, approximately 2" away from each side of pivot bunk mounting bracket as shown in **Detail M**. When fastening the clamps together, use clamp with pressed in hex nuts as bottom clamp. Fine adjust bunks to fit the hull of your boat as needed.
3. Attach wood bunks as shown in **Detail N**. Insure the left and right bunk support angles are installed between each pivot bunk mounting bracket and wood bunk. Mount the bunks with carpeted seams facing each other at the ends and edge seam openings facing down against bunk support angle.
4. Make fine adjust of bunks to fit the hull of your boat after final assembly and installation in water.



CAUTION:

WHEN FASTENING CLAMPS TO LIFTING AND TRAILING ARMS, INSURE THAT THE ATTACHED BUNK BEARING HOUSINGS DO NOT CAUSE ANY BINDING WHEN THE PLATFORM IS RAISED OR LOWERED.

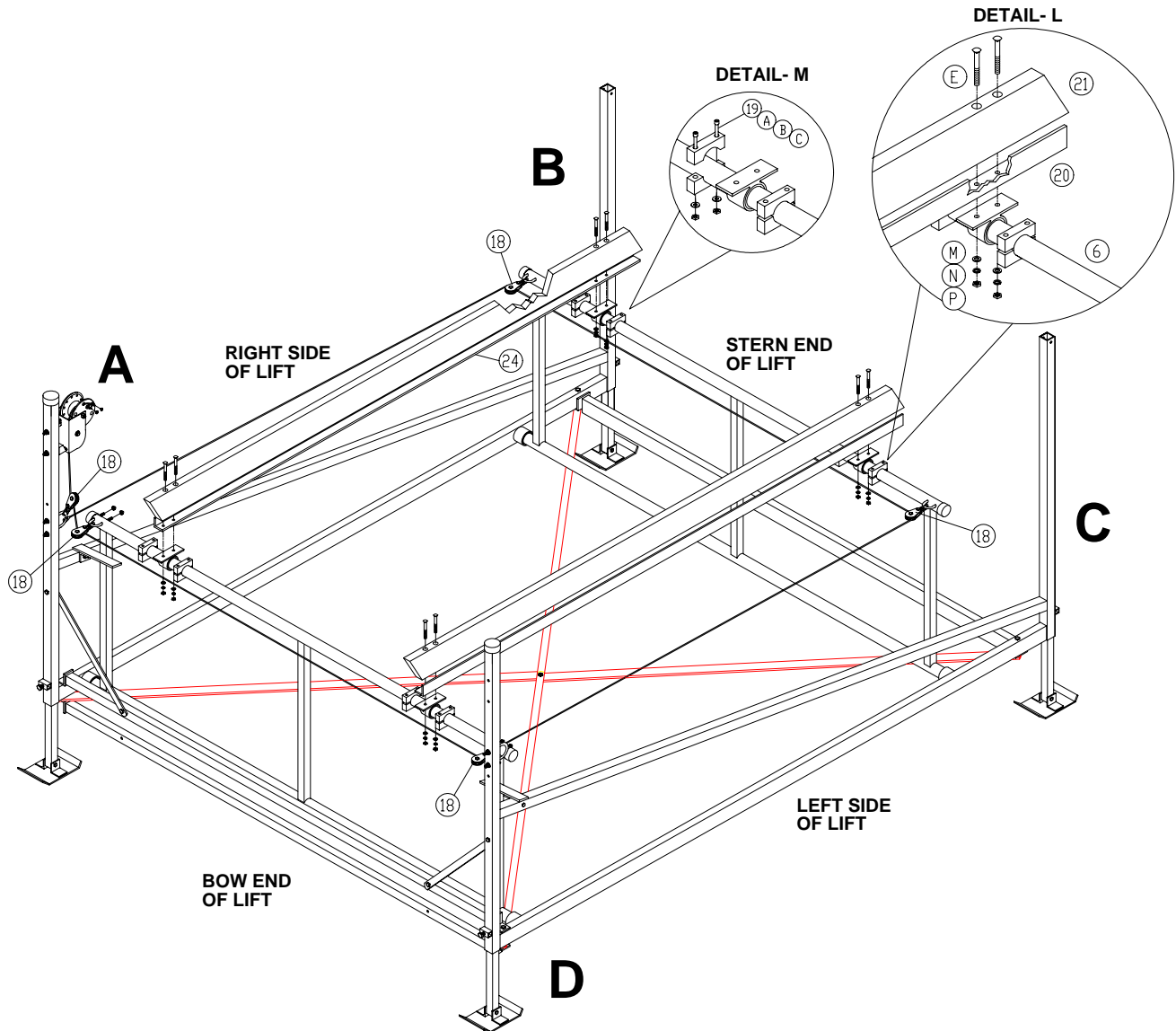

Figure 3-5.
Wood Bunk Assembly

3.9 ADJUSTING THE LIFT

1. Refer to **Figure 3-1**. Adjust extension legs to height required to keep lift level in its operating position. Tighten with lock screw at all four corners of lift as shown in **Detail B**.
2. Insure the frame is square. Then tighten all hardware before trying to operate the lift.



CAUTION:
DO NOT EXCEED THE MAXIMUM TORQUE RATING ON ALL BOLTS OF 20 FT-LBS.



CAUTION:
INSURE LIFT IS SQUARE AND LEVEL BEFORE OPERATING. LIFT IS SQUARE WHEN DIAGONAL MEASUREMENTS ARE EQUAL.

3.10 FINAL ASSEMBLY CHECKLIST

The lift and related equipment must be thoroughly inspected prior to each use. Only those who have read and understand this entire manual and related equipment manuals are qualified to do this inspection. This checklist is to be used as a guideline in conjunction with the maintenance and inspection procedures outlined in Chapter 5. It is recommended that the inspection be maintained as a permanent record.

- When facing the front of the handwheel, insure that clockwise rotation of handwheel raises lift, and counter clockwise rotation lowers the lift.
- Insure the brake pawl clicks, indicating that the brake is operative.
- Insure the winch wire rope is not rubbing against the inside of the winch or the vertical leg.
- Insure that the wood bunks and clamps are installed as specified in Section 3.8 of this manual.
- Insure all bolts and pulleys are fastened securely prior to operation.
- Insure the pulleys spin freely. If any pulley binds replace it immediately.
- Insure the lift installation will clear all obstructions.
- Insure all structural members of the lift are free of defects and damage that may affect the integrity of the unit.
- Insure the lift is not being used beyond its rated capacity of 2000 lbs.
- Insure that any user or dealer installed locking devices have been removed before operating the lift.
- Insure the legs are properly adjusted for the lowest platform position relative to the water.
- Insure the frame is square and the lift is sitting level.
- Insure the boat is properly positioned (centered) on the lift before doing any raising or lowering.
- Operate the lift first without, and then with, your boat on the platform to test the operation of both the lift and the winch.
- Conduct the wire rope inspection procedure described in Chapter 5 at least once per month.

4 OPERATION

4.1 BEFORE OPERATING THE LIFT

1. Read and know the instructions and insure that everyone understands the proper operating procedure.
2. Do not use the lift if it shows any signs of damage.
3. Insure that all bolts and nuts are fastened securely prior to operation.
4. Check that the winch is reeved properly. See reeving instructions in Chapter 3 of this manual.
5. Never try lifting anything other than a boat with this lift.



WARNING:

NEVER TRY TO USE THIS EQUIPMENT BEYOND ITS RATED 2000 POUND CAPACITY. THIS CAN DAMAGE THE LIFT AND/OR BOAT RESULTING IN PERSONAL INJURY.

THE BOAT MUST BE PROPERLY SECURED ON THE LIFT BEFORE DOING ANY RAISING OR LOWERING. FAILURE TO DO THIS CAN CAUSE EQUIPMENT DAMAGE AND/OR PERSONAL INJURY.



CAUTION:

NEVER TRY TO LIFT OR LAUNCH YOUR BOAT IN ROUGH WATER CONDITIONS. THIS CAN DAMAGE YOUR BOAT AND/OR THE LIFT.

6. Do not operate the lift under the influence of drugs, alcohol, or medication.
7. Completely remove any user or dealer installed locking devices prior to use.

4.2 TESTING WINCH OPERATION

After the lift installation is complete, it is important that the winch functions properly. Test the winch operation as follows:

1. Raise the empty platform about one-fourth the way up and release the handwheel. If the winch is functioning properly, the brake mechanism will hold the platform at any position. The handwheel must turn clockwise when raising the platform. The brake pawl must click, indicating that the brake is operative.



WARNING:

IF YOU HAVE TO TURN THE HANDWHEEL COUNTERCLOCKWISE TO RAISE THE PLATFORM, YOU HAVE REEVED THE WINCH INCORRECTLY. YOU WILL IMMEDIATELY ENCOUNTER STRONG RESISTANCE WHICH CAN LEAD TO WINCH DAMAGE AND/OR WIRE ROPE BREAKAGE.

2. Repeat Step 1 in the half, three-quarters, and full lift positions.



WARNING:

IF THE HANDWHEEL STARTS TO FREELY SPIN DOWN FROM ANY OF THESE TEST POSITIONS, NEVER TRY TO STOP IT. DO NOT USE A LIFT IN THIS CONDITION.

3. Lower the empty platform to repeat steps 1 and 2 with your boat on the lift. The handwheel must turn counter-clockwise when lowering the platform. This counter-clockwise rotation allows the self-activating brake mechanism

to stop the platform lowering as soon as the operator stops turning the handwheel. Make sure this brake mechanism is operative.



WARNING:

IF YOU HAVE TO LOWER THE PLATFORM BY TURNING THE HANDWHEEL CLOCKWISE, YOU HAVE REEVED THE WINCH INCORRECTLY. THE BRAKE PAWL WILL NOT BE EFFECTIVE WHICH CAN CAUSE AN UNCONTROLLED SPIN-DOWN OR “FREEWHEEL” OF THE HANDWHEEL.

4. Contact your authorized dealer if the winch mechanism fails to perform as described in this section.



CAUTION:

NEVER TAMPER WITH THE WINCH MECHANISM. THIS CAN CAUSE EQUIPMENT DAMAGE THAT WILL INVALIDATE YOUR WARRANTY.

4.3 RAISING AND LOWERING THE PLATFORM

1. Raise the platform by turning the handwheel clockwise. Do **not** use the spinner knob; it is to be used for lowering only. The self-activating brake mechanism will hold the platform at any desired height.



WARNING:

DO NOT CONTINUE TO RAISE THE BOAT AFTER THE PLATFORM REACHES MAXIMUM LIFTING HEIGHT. THIS WILL CAUSE EQUIPMENT DAMAGE AND/OR PERSONAL INJURY.

2. Lower the platform by turning the handwheel counterclockwise. The spinner knob may be used if desired.



WARNING:

NEVER RELEASE THE BRAKE PAWL OF THE WINCH. THIS WILL CAUSE AN UNCONTROLLED SPIN-DOWN OR “FREEWHEEL” OF THE HANDWHEEL.

DO NOT CONTINUE LOWERING THE PLATFORM AFTER THE BOAT FLOATS FREELY FROM THE PLATFORM OR IF THE WINCH WIRE ROPE GOES SLACK. THIS MAY CAUSE LIFT AND WINCH DAMAGE.

3. Keep fingers and clothing clear of all moving parts. Keep people clear during operation of the lift.
4. Never allow people in the boat any time it is suspended above the water on the lift.



WARNING:

DO NOT STAND OR WALK ON THE LIFT PLATFORM WHILE IT IS IN ANY RAISED POSITION. THIS CAN CAUSE SERIOUS PERSONAL INJURY.

5. Check the lift periodically for frayed wire rope and/or binding pulleys.

4.4 SECURING LIFT WHEN NOT IN USE

At the end of operation, secure the lift to prevent unauthorized use by raising the platform to the desired height and padlocking the handwheel to the post.

5 INSPECTION AND MAINTENANCE

5.1 GENERAL MAINTENANCE RULES



WARNING:

NEVER PERFORM WORK IN OR ON THE BOAT WHEN IT IS SUSPENDED ABOVE THE WATER ON THE PLATFORM.



CAUTION:

POOR OR IMPROPER MAINTENANCE CAN LEAD TO EQUIPMENT DAMAGE OR FAILURE.

1. Do not weld or otherwise modify the lift. Such alterations may weaken the structural integrity of the lift and invalidate your warranty.
2. Completely lower the platform before performing any type of maintenance or repair.

5.2 WIRE ROPE INSPECTION PROCEDURE

Inspect the wire rope at least once per month for signs of wear, damage, or pinching. Inspect the entire wire rope working length. Thoroughly inspect the rope sections that pass over pulleys or drums, or that make opposing turns. Inspect wire rope and end attachments carefully. While inspecting, examine pulleys, guards, guides, drums, flanges, and other surfaces contacting wire rope during operation. Correct any condition harming the rope in use or other damage or worn surfaces at this time.



WARNING:

WEAR HEAVY LEATHER GLOVES WHEN HANDLING WIRE ROPE. INSUFFICIENT HAND PROTECTION WHEN HANDLING WIRE ROPE CAN CAUSE SERIOUS PERSONAL INJURY.

Remove and immediately replace wire rope with one or more of the following defects:

1. Corrosion (wire rope degrades starting from inside).
2. Broken wires: (See Figure 5-1.)
 - (a) One or more valley breaks. A valley break is a wire break occurring in the valley between two adjacent strands.
 - (b) Six randomly distributed broken wires in one rope lay. A rope lay is the length of rope along which one strand makes a complete revolution around the rope. Keeping the rope clean and wound evenly on the winch drum will increase its life and efficiency.
3. Abrasion: Scrubbing, flattening or peening causing loss of more than one-third of the original diameter of the outside wires.
4. Kinking: Severe kinking, crushing, bird caging or other damage causing distortion of the rope structure. Bird caging is a bulging in the wire rope caused by the individual wires becoming untwisted. This untwisting of individual wires is usually caused by impact loading on the wire rope.
5. Heat damage: Evidence of any heat damage caused by a torch or by contact with electrical wires.
6. Reduction of more than 3/64 inch from 1/4 inch diameter wire rope, 1/16 inch from 5/16 or 3/8 inch diameter wire rope. Marked reduction in diameter indicates core deterioration.

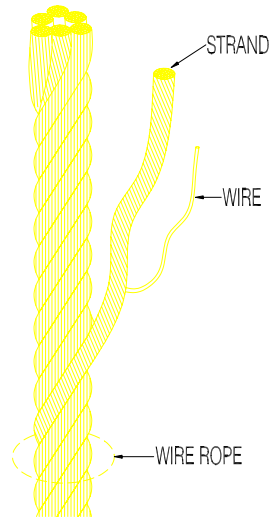

Figure 5-1.
Wire Rope Components

5.3 ANNUAL INSPECTION

At least once a year, the lift must be thoroughly inspected using the following procedure.



WARNING:
DO NOT ALLOW ANYBODY TO USE THE LIFT UNTIL THIS MAINTENANCE IS COMPLETED.

1. Tighten all bolts.
2. Check the pulleys to insure that they spin freely. If they bind, replace them immediately.
3. Check frame thoroughly for defects.
4. Perform the winch maintenance as described in Section 5.4.

5.4 ANNUAL WINCH MAINTENANCE



WARNING:
THE WINCH MAINTENANCE SCHEDULE MUST BE FOLLOWED TO AVOID POSSIBLE EQUIPMENT FAILURE OR PERSONAL INJURY.

1. Apply automotive type grease to both the pinion and drum gear teeth, and to the outside diameter of the drum bearing. Always keep this light film of grease on the gear teeth.
2. During each usage, check for proper ratchet operation as follows: When lifting with clockwise rotation, a loud clicking sound should be heard. When lowering with counter-clockwise rotation, there is no clicking sound.



WARNING:
AFTER EVERY WINCH MAINTENANCE, TEST THE WINCH MECHANISM AS DESCRIBED IN CHAPTER 4 BEFORE LETTING ANYONE USE THE LIFT.

5.5 STORAGE PROCEDURE

1. Protect your lift as far as possible from damage caused by environmental factors such as airborne fallout, chemicals, tree sap, and weather hazards.
2. Never use the lift to hang or store any auxiliary equipment such as boating hardware.
3. Do not allow anyone to swim or play near the lift at any time.
4. Padlock the handwheel to the post when your boat lift is unattended. Never assume you will find the lift in the same condition that you left it.

6 TROUBLESHOOTING

The following chart is intended to assist with troubleshooting your boat lift. While not all inclusive, the chart outlines the most common causes of a problem and the recommended course of action.

SYMPTOM	CAUSE AND CORRECTIVE ACTION
Winch wire rope is rubbing against inside of winch or against vertical leg.	<p>Winch wedge has not been installed on a right-sided winch mounting—see Section 3.5.</p> <p>Winch has been incorrectly reeved on a right-sided winch mounting—see Section 3.7.</p>
Winch wire rope is not rubbing against any part of the winch or lift frame, but winch is resisting platform raising.	Winch has been reeved incorrectly—winch must turn clockwise to raise platform.—see Section 3.7.
Winch fails to hold the platform in a given position as described in the test procedure of Section 4.2	Contact your authorized dealer—tampering with the winch mechanism can cause equipment damage that may invalidate your warranty.
Winch is operating properly, but platform raising is either difficult or impossible.	<p>Platform is binding because frame is either not square or not set level in the water—refer to Section 3.9.</p> <p>Wire rope is broken—replace wire rope.</p> <p>Wire rope is excessively worn—replace and follow monthly wire rope inspection procedure described in Section 5.2.</p> <p>One or more pulleys are binding—replace these immediately.</p> <p>Load exceeds rated capacity of 2000 lbs.— reduce load weight as needed.</p> <p>User or dealer installed locking devices are in place—remove these.</p> <p>Auxiliary equipment such as boating hardware is being improperly hung on lift—remove this equipment permanently.</p> <p>Wood bunks are binding on the platform—move and re-clamp arm plates as needed.</p>
Boat lift is not lifting level—stern is lifting higher or lower than the bow.	Frame is not level in the water—adjust the frame as described in Section 3.9.
Boat lift shifts position when operating the lift.	Boat is not properly positioned on the lift—failure to properly position boat can cause equipment damage and/or serious personal injury.
Lowering operation triggers a “freewheeling” of the handwheel.	Winch has been reeved incorrectly—winch must turn counterclockwise to lower the platform. See Section 3.7.

Lowering operation triggers a “freewheeling” of the handwheel. (continued)	Unauthorized brake pawl release has occurred—do not try to correct this yourself. Contact your authorized dealer immediately.
Lowest platform position is too high or low relative to the water.	Legs not adjusted properly—see Section 3.9.
Platform is not lowering completely.	Stern cross tie is incorrectly mounted to the topside of the side assemblies—refer to Section 3.4.
Platform does not stop in the proper position during raising.	Stop angle is not stopping the lifting arm because bow cross tie is incorrectly mounted to the underside of the side assemblies—refer to Section 3.4.

7 PARTS LIST

Each reference number or letter in the following parts list can be matched with the reference number or letter referred to in both the text and illustrations of Chapter 3, Installation and Setup.

7.1 PL2000 BOAT LIFT

REF #	PART #	QTY	DESCRIPTION
1	3403726	4	FOOT PLATE
2	3403732	4	EXTENSION LEG 18"
3	3406675	4	CROSS DIAGONAL
4	3406520	1	SIDE FRAME ASSEMBLY—LEFT HAND
5	3406525	1	SIDE FRAME ASSEMBLY—RIGHT HAND
6	3406510	2	LIFTING ARM ASSEMBLY
7	6403713	4	PLASTIC CAP 2" OD X 1/4W
8	3406505	2	FRONT CROSS TIE
9	3406530	1	REAR CROSS TIE
10	3406660	2	FRONT DIAGONAL SUPPORT
11	3402535	2	TOP TRAVEL STOP
12	3402410	1	WINCH BACKER PLATE
13	3403724	1	WINCH WEDGE
14	3402425	1	WINCH
15	3402405	1	WINCH STIFFENER PLATE
16	3703803	1	HANDWHEEL 4'
17	3671010	1	HANDWHEEL SPINNER KNOB ASSEMBLY
18	7303157	6	POLYMER BLOCK
19	3403753	8 Pairs	BUNK COLLAR
20	3406665	1	BUNK SUPPORT ANGLE—LEFT HAND
21	3406305	2	BUNK ASSEMBLY
22	3406405	1	CABLE ASSEMBLY
23	3703142	1	WINCH CABLE CLAMP KIT
24	3406670	1	BUNK SUPPORT ANGLE—RIGHT HAND
A	5896956	16	1/4-20 X 2-3/4" HHCS
B	5896392	16	1/4 WASHER FLAT USS
C	5896373	16	1/4-20 HEX NUT
D	5896217	4	3/8-16 X 1-1/4" CARRIAGE BOLT
E	5893601	8	3/8-16 X 8" CARRIAGE BOLT
F	5896253	7	3/8-16 X 2-1/2" HHCS
G	5896255	4	3/8-16 X 3" HHCS
H	5896257	1	3/8-16 X 3-1/2" HHCS
I	5896262	1	3/8-16 X 4-1/2" HHCS
K	5896264	4	3/8-16 X 5-1/2" HHCS
L	5896081	6	3/8-16 X 3-1/2" U-BOLT
M	5896406	30	3/8 WASHER FLAT SAE
N	5806243	30	3/8 WASHER SPLIT LOCK
O	5806266	8	3/8 ACORN NUT
P	5896377	30	3/8-16 HEX NUT
Q	5897016	4	3/8-16 NYLOCK HEX NUT
R	6408069	6	PLASTIC CAP 11/32 X 1/2L
S	5896283	4	1/2-13 X 1-3/4" HHCS
T	5896385	4	1/2-13 SQUARE NUT

LIMITED WARRANTY

Reimann & Georger Corporation MARINE PRODUCTS

Reimann & Georger Corporation, hereafter referred to as the “Manufacturer”, extends this limited warranty to the original purchaser of this product. The original purchaser, hereinafter referred to as the “Buyer”, is defined as the first legal owner of this product other than an authorized distributor or dealer who has bought the product from the Manufacturer for resale to the public. **The Buyer must complete and return the Warranty Registration section of the provided Warranty Card to make this limited warranty effective.**

CONSUMER PRODUCT PROVISIONS

I. ARTICLE I—CONSUMER PRODUCT PROVISIONS: THE FOLLOWING PROVISIONS SHALL BE APPLICABLE IF THIS PRODUCT IS BEING PURCHASED FOR PERSONAL, FAMILY OR HOUSEHOLD PURPOSES.

THE CONSUMER PRODUCT PROVISIONS CONTAINED IN THIS ARTICLE I SHALL APPLY UNLESS THIS PRODUCT IS BEING PURCHASED SOLELY FOR COMMERCIAL OR INDUSTRIAL USE, IN WHICH EVENT THE PROVISIONS CONTAINED IN ARTICLE II BELOW SHALL APPLY AND THE PROVISIONS CONTAINED IN THIS ARTICLE I SHALL BE INAPPLICABLE.

A. 2-YEAR LIMITED WARRANTY

The Manufacturer warrants to the Buyer that all supplied parts shall be free of defects in material and workmanship for a period of two (2) years from date of original purchase. This limited warranty covers the cost of all parts and labor needed to repair any item that is found to be defective in material and workmanship. Items covered include cables, sheaves, chains, motors, reducers, switches, control panels and ground fault circuit interrupters.

B. 15-YEAR LIMITED WARRANTY ON VL/PL SERIES ALUMINUM FRAME EXTRUSION

The Manufacturer warrants to the Buyer that the frame and extrusions shall be free of defects in material and workmanship for a period of fifteen (15) years from date of original purchase. This limited warranty covers the cost of all parts and labor needed to repair any item that is found to be defective in material and workmanship.

C. MANUFACTURER’S OBLIGATIONS

The Manufacturer’s sole obligation under either of these limited warranties is the replacement or repair, at the Manufacturer’s discretion, of parts found to be defective.

D. NO SPECIAL, INCIDENTAL OR CONSEQUENTIAL DAMAGES

IN NO EVENT SHALL THE MANUFACTURER BE LIABLE TO THE BUYER OR ANY PERSON FOR ANY INDIRECT, SPECIAL, INCIDENTAL, OR CONSEQUENTIAL LOSSES OR DAMAGES CONNECTED WITH THE USE OF THE PRODUCT UNDER WARRANTY. SUCH DAMAGES FOR WHICH THE MANUFACTURER SHALL NOT BE RESPONSIBLE INCLUDE, BUT ARE NOT LIMITED TO, LOST TIME AND CONVENIENCE, LOSS OF USE OF THE PRODUCT, THE COST OF A PRODUCT RENTAL, COSTS OF GASOLINE, TELEPHONE, TRAVEL, OR LODGING, THE LOSS OF PERSONAL OR COMMERCIAL PROPERTY, AND THE LOSS OF REVENUE.

Some States do not allow the exclusion or limitation of incidental or consequential damages, so the above limitation or exclusion may not apply to you.

E. NO LIABILITY IN EXCESS OF PURCHASE PRICE

IN NO EVENT SHALL THE MANUFACTURER’S OBLIGATIONS UNDER THIS LIMITED WARRANTY EXCEED THE PURCHASE PRICE OF THE PRODUCT.

F. NO EXTENSION OF STATUTE OF LIMITATIONS

ANY REPAIRS PERFORMED UNDER EITHER OF THESE WARRANTIES SHALL NOT IN ANY WAY EXTEND THE TWO-YEAR AND FIFTEEN-YEAR STATUTES OF LIMITATIONS CONTAINED IN THIS LIMITED WARRANTY.

G. PROCEDURE FOR WARRANTY PERFORMANCE

If the product fails to perform to the Manufacturer's specifications, the Buyer must contact the dealer from whom the product was purchased. The Buyer must provide the dealer with the applicable model and serial numbers, the date of purchase, and the nature of the problem.

H. PREAPPROVAL OF LABOR COSTS

All labor costs related to a dealer's performance of the warranty obligations under this limited warranty must be pre-approved by Reimann & Georger Corporation

I. NO OTHER EXPRESS WARRANTIES

THE MANUFACTURER IS NOT SUBJECT TO ANY EXPRESS WARRANTIES OTHER THAN THOSE SET FORTH ABOVE.

J. LIMIT ON DURATION OF IMPLIED WARRANTIES

THE DURATION OF ANY IMPLIED WARRANTIES UNDER APPLICABLE STATE LAW RELATING TO THE PURCHASE OF THIS PRODUCT SHALL BE LIMITED TO A PERIOD OF TWO (2) YEARS FROM THE DATE OF PURCHASE.

Some States do not allow limitations on how long an implied warranty lasts, so the above limitations may not apply to you.

K. QUESTIONS REGARDING LIMITED WARRANTY

Any questions regarding this limited warranty or the procedure which the consumer should follow in order to obtain performance of any warranty obligation may be addressed to either the dealer from whom this product is purchased or to Reimann & Georger Corporation, P.O. Box 681, Buffalo, NY 14240.

L. EXCLUSIONS FROM LIMITED WARRANTY. THIS LIMITED WARRANTY DOES NOT COVER ANY OF THE FOLLOWING:

1. Equipment which has been abused, damaged, used beyond rated capacity, or which is damaged or has defects caused by repairs or service completed by persons other than authorized service personnel.
2. Costs of repairing damage caused by environmental factors which include, but are not limited to, airborne fallout, chemicals, tree sap, salt, ocean spray, and water hazards.
3. Damage caused by acts of God which include, but are not limited to, hailstorms, windstorms, tornadoes, sandstorms, lightning, floods, and earthquakes.
4. Damage under conditions caused by fire or accident, by abuse or negligence, by improper installation, by misuse, by incorrect operation, by "normal wear and tear", by improper adjustment or alteration, by alterations not done by the Manufacturer, or by failure of product parts from such alterations.
5. Costs of repairing damage caused by poor or improper maintenance, costs of normally scheduled maintenance, or the cost of replacing any parts unless done as the result of a repair covered by your two-year limited warranty.

6. Costs of modifying the product in any way once delivered to the Buyer, even if such modifications were added as a production change on other products made after the Buyer's product was built.

M. RIGHT TO MODIFY PRODUCT

The Manufacturer has the right to modify this product at any time without incurring any obligation to make the same or similar modifications on products previously purchased.

N. NO AUTHORITY TO ALTER WARRANTY

No agent, representative, distributor or dealer has any authority to alter the terms of this warranty in any way.

O. SPECIFIC LEGAL RIGHTS

This warranty gives you specific legal rights and you may also have other rights which vary from State to State.

COMMERCIAL PRODUCT PROVISIONS

II. ARTICLE II—COMMERCIAL PRODUCT PROVISIONS: THE FOLLOWING PROVISIONS SHALL BE APPLICABLE ONLY IF THIS PRODUCT IS BEING PURCHASED SOLELY FOR COMMERCIAL OR INDUSTRIAL USE. IF THIS PRODUCT IS BEING PURCHASED FOR PERSONAL, FAMILY OR HOUSEHOLD PURPOSES, THE PROVISIONS CONTAINED IN THIS ARTICLE II SHALL NOT BE APPLICABLE AND THE PROVISIONS CONTAINED IN ARTICLE I ABOVE SHALL APPLY.

A. 1-YEAR LIMITED WARRANTY

The Manufacturer warrants to the Buyer that all supplied parts shall be free of defects in material and workmanship for a period of one (1) year from date of original purchase. This limited warranty covers the cost of all parts and labor needed to repair any item that is found to be defective in material and workmanship. Items covered include cables, sheaves, chains, motors, reducers, switches, control panels and ground fault circuit interrupters.

B. 5-YEAR LIMITED WARRANTY ON VL/PL SERIES ALUMINUM FRAME EXTRUSION

The Manufacturer warrants to the Buyer that the frame and extrusions shall be free of defects in material and workmanship for a period of five (5) years from date of original purchase. This limited warranty covers the cost of all parts and labor needed to repair any item that is found to be defective in material and workmanship.

C. MANUFACTURER'S OBLIGATIONS

The Manufacturer's sole obligation under either of these limited warranties is the replacement or repair, at the Manufacturer's discretion, of parts found to be defective.

D. NO SPECIAL, INCIDENTAL, OR CONSEQUENTIAL DAMAGES

IN NO EVENT SHALL THE MANUFACTURER BE LIABLE TO THE BUYER OR ANY PERSON FOR ANY INDIRECT, SPECIAL, INCIDENTAL, OR CONSEQUENTIAL LOSSES OR DAMAGES CONNECTED WITH THE USE OF THE PRODUCT UNDER WARRANTY. SUCH DAMAGES FOR WHICH THE MANUFACTURER SHALL NOT BE RESPONSIBLE INCLUDE, BUT ARE NOT LIMITED TO, LOST TIME AND CONVENIENCE, LOSS OF USE OF THE PRODUCT, THE COST OF A PRODUCT RENTAL, COSTS OF GASOLINE, TELEPHONE, TRAVEL, OR LODGING, THE LOSS OF PERSONAL OR COMMERCIAL PROPERTY, AND THE LOSS OF REVENUE.

E. NO LIABILITY IN EXCESS OF PURCHASE PRICE

IN NO EVENT SHALL THE MANUFACTURER'S OBLIGATIONS UNDER THIS LIMITED WARRANTY EXCEED THE PURCHASE PRICE OF THE PRODUCT.

F. NO EXTENSION OF STATUTE OF LIMITATIONS

ANY REPAIRS PERFORMED UNDER EITHER OF THESE WARRANTIES SHALL NOT IN ANY WAY EXTEND THE RESPECTIVE STATUTES OF LIMITATIONS CONTAINED IN THIS LIMITED WARRANTY.

G. WAIVER OF OTHER WARRANTIES

THESE EXPRESS WARRANTIES ARE IN LIEU OF AND EXCLUDE ANY AND ALL OTHER WARRANTIES, EXPRESS OR IMPLIED, INCLUDING, BUT NOT LIMITED TO, THE IMPLIED WARRANTIES OR MERCHANTABILITY AND FITNESS FOR A PARTICULAR PURPOSE.

H. PROCEDURE FOR WARRANTY PERFORMANCE

If the product fails to perform to the Manufacturer's specifications, the Buyer must contact the dealer from whom the product was purchased. The Buyer must provide the dealer with the applicable model and serial numbers, the date of purchase, and the nature of the problem.

I. PREAPPROVAL OF LABOR COSTS

All labor costs related to a dealer's performance of the warranty obligations under this limited warranty must be pre-approved by Reimann & Georger Corporation.

J. EXCLUSIONS FROM WARRANTY. THIS LIMITED WARRANTY DOES NOT COVER ANY OF THE FOLLOWING:

1. Equipment which has been abused, damaged, used beyond rated capacity, or which is damaged or has defects caused by repairs or service completed by persons other than authorized service personnel.
2. Costs of repairing damage caused by environmental factors which include, but are not limited to, airborne fallout, chemicals, tree sap, salt, ocean spray, and water hazards.
3. Damage caused by acts of God which include, but are not limited to, hailstorms, windstorms, tornadoes, sandstorms, lightning, floods, and earthquakes.
4. Damage under conditions caused by fire or accident, by abuse or negligence, by improper installation, by misuse, by incorrect operation, by "normal wear and tear", by improper adjustment or alteration, by alterations not done by the Manufacturer, or by failure of product parts from such alterations.
5. Costs of repairing damage caused by poor or improper maintenance, costs of normally scheduled maintenance, or the cost of replacing any parts unless done as the result of a repair covered by your one-year limited warranty.
6. Costs of modifying the product in any way once delivered to the Buyer, even if such modifications were added as a production change on other products made after the Buyer's product was built.

K. RIGHT TO MODIFY PRODUCT

The Manufacturer has the right to modify this product at any time without incurring any obligation to make the same or similar modifications on products previously purchased.

L. NO AUTHORITY TO ALTER WARRANTY

No agent, representative, distributor, or dealer has any authority to alter the terms of this warranty in any way.

M. SPECIFIC LEGAL RIGHTS

This warranty gives you specific legal rights, and you may also have other rights which vary from State to State.